

Sunny Island 4248U



SMA's new off grid inverter - A technological leap into the future



- Optimized for high ambient temperatures
- Very high overload capability
- High efficiency
- Integrated DC breaker
- Intuitive user interface
- Output load shedding
- DC and AC coupling of energy sources
- Nearly silent operation
- Automatic generator start
- Battery protection
- Insect proof
- Easy installation and commissioning
- Non volatile parameter settings
- Compatible with the Sunny Family of products

The new Sunny Island 4248U battery based inverter is the first off-grid inverter from SMA for use in the U.S. Perfect sine wave off-grid electricity is now available with high efficiency, robust power and outstanding reliability. Simple to install and use, yet loaded with powerful and advanced features, the Sunny Island 4248U is designed to meet the needs of off-grid as well as back-up power system applications.

Whenever and wherever electric power is needed, the new Sunny Island 4248U will perform!



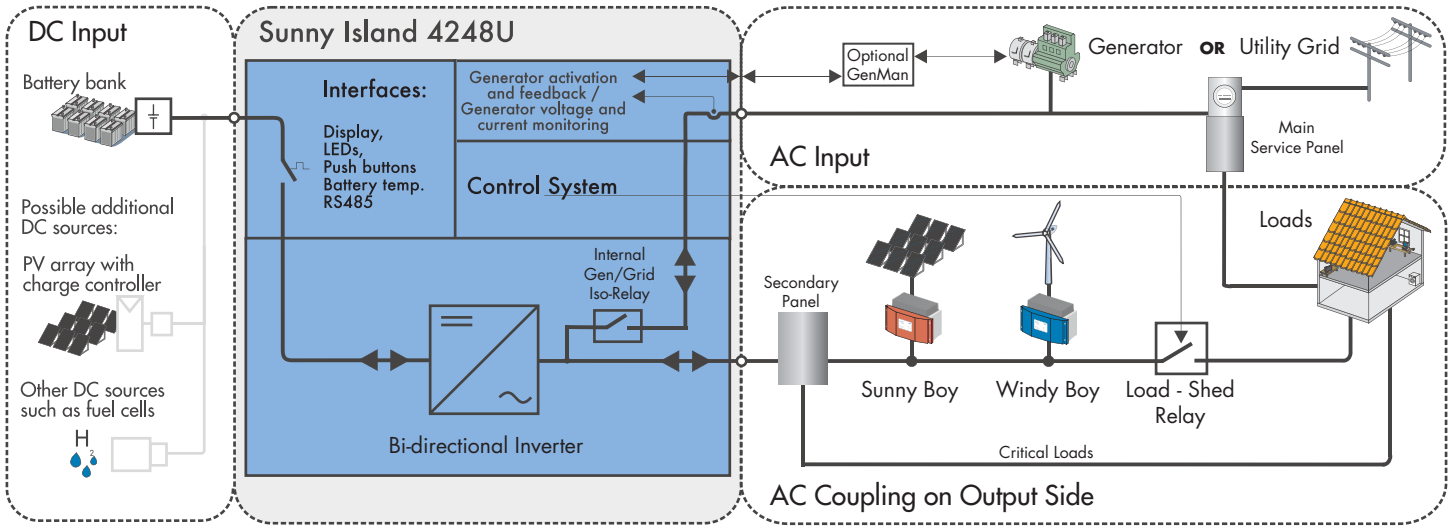

The Sunny Island 4248U provides a continuous power output of 4200 watts at 25°C and 3400 watts even at scorching temperatures up to 45°C. That's enough power to comfortably energize most household appliances with power to spare. Large critical loads such as water pumps and refrigerators can be easily powered by the Sunny Island 4248U. This inverter operates silently and can be powered from multiple sources: wind, utility grid (for back-up power), hydro, solar electric and is even compatible with fuel cells. A number of communication options provide flexible remote system monitoring. The optional SMA "GenMan" (Generator Management Box) provides advanced control of even the most basic generators. The Sunny Island 4248U also works in conjunction with grid tied Sunny Boy solar systems to provide a powerful and efficient back up power solution.

The internal battery charger can supply up to 100A to the battery when in charge mode. Transition from charge to invert mode is a lightning fast 20ms, so even your computers will stay on-line. A pass-through relay with a rating of 60A at 120V is also included. Two Sunny Island 4248's may be paralleled to support 240VAC split-phase load centers. Once installed, the Sunny Island 4248U will run with basically no maintenance for years to come. With its state-of-the-art software and non-volatile memory, just set it and forget it.

Technical Data

Electrical / Mechanical data

Nom. Battery Voltage:	VDC,nom	48 V
Battery Voltage Range:	VDC	41 - 63 V
Nom. AC Voltage:	VAC,nom	120 V
AC Voltage Range:	VAC	105 - 132 V
Nom. AC Frequency:	fAC,nom	60 Hz
AC Input Charge Current:	IAC,chg	40A @ 25°C 28A @ 45°C
Max. AC pass through current (transfer relay):		60 A
Consumption (no load operation):		<22 W
Consumption (standby):		<4 W
Total harmonic distortion:		<3 %

Temperature Range

-20°C to +45°C / -4.0°F to +113.0°F

Enclosure: IP30

Weight: 39 kg / 86 lbs

Size: W 390 x L 590 x H 245 millimeters
W 15.35 x L 23.22 x H 9.64 inches

Interfaces

- 2 LEDs; 2-line LCD; 4 push buttons
- 1 dry contact output for load shedding
- 1 dry contact for generator start
- 1 generator-ready opto isolated input

Accessories

- Remote battery temperature sensor (included)
- Generator Management Box (optional)
- 1 RS232/485 galvanic isolated for communication(optional)

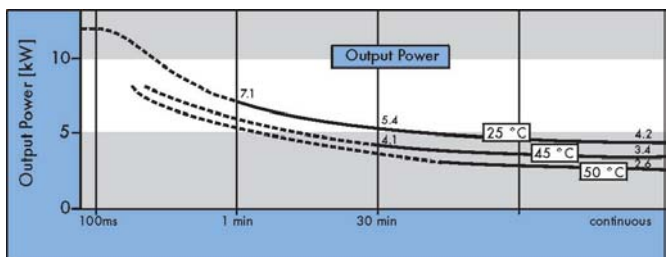
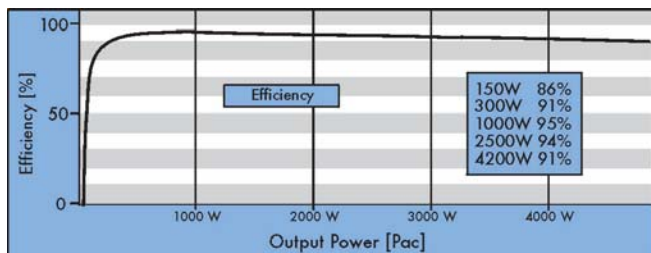

SMA America, Inc.
12438 Loma Rica Drive
Grass Valley, CA 95945
phone: 530.273.4895
email: info@sma-america.com
www.sma-america.com

DC Power Systems
(800) 967-6917
www.dcpower-systems.com

Solar Today ...
Energy Tomorrow **SMA**